

Model: SDF-1106-01

1%RH, 1708L



SDF-1106-01 has a large capacity with deep design, perfect ultra-low humidity storage for tapes feeders. Humidity can be controlled precisely by digital panel to reach the lowest 1%RH. It is specially designed for moisture sensitive SMD packages to comply with IPC/JEDEC J-STD-033D.

Totech (Toyo Living) is the creator of world's first Automatic Drying System invented in 1973.

Super Dry cabinets use the highly-quality and highly reliable Toyo Living engine and has been sold over 700,000 units and used in over 10,000 companies around the world. We also supply various kinds of custom-build cabinet to best suit our client's need.

Features

- ❖ Modular design: Totech Super Dry is modularly designed dry cabinet. The main modules include dry units, control box, sensor, shelves and castors. All of the modules can be replaced easily. Totech dry cabinet can be used as long as the cabinet structure is in good condition. Most of our customers can use the Totech dry cabinets for more than 10 years without any problem.

❖

- ❖ ESD safe design: Cabinet is with ESD metal painted steel body and ESD safe steel shelves and ground wire, well comply with IEC 61340-5-1.

- ❖ Convenient Operation: Totech Super Dry cabinet is with digital control panel, can control the humidity precisely from 1% to 50%RH, by adjusting $\pm 0.1\%RH$. Humidity, temperature and alarm functions are shown and can be adjusted by digital control panel. Key Lock function on the digital control panel prevents unintended changes of setting. Sensor calibration function is also available with digital panel.

- ❖ Maintenance free design: Totech dry cabinet works by dry units. An interlocked fan causes the air to circulate through the dry unit, while passing through the dry unit moisture in the air is absorbed by the zeolite desiccant. During periodic regenerating of the zeolite desiccant by heating, the absorbed humidity is evaporated and exhausted through the external shutters of the dry unit. The process is physical, and no extra maintenance at all.

- ❖ Lockable doors: Every door can be locked separately with a key.

- ❖ Alarm setting (Options): Humidity/door open alarm buzzer and humidity alarm light tower.

Applications

SUPER DRY maintains preset internal humidity levels from 1~50%RH and is ideal for moisture-proof and anti-oxidation storage applications, offering protection from corrosion, mold and deterioration for such items as:

- ❖ Tape materials on feeders.
- ❖ All kinds of Integrated Circuits (IC), like Monolithic, BGA, QFP; PLCC, Bipolar etc.
- ❖ Silicon Wafers.
- ❖ Aerospace related Instruments and Tools.
- ❖ Optical Equipment and Machine Tools.
- ❖ Watches.

Specifications

Humidity Range	1%~50%RH
Sensor precision	$\pm 2\%RH, \pm 1^\circ C$
External dimensions	(W x H x D) 1200 x 1840 x 960 mm
Internal dimensions	(W x H x D) 1190 x 1560 x 910 mm
Weight	197 kg
Capacity	1708 L
Shelves (W x D)	5 pcs, adjustable
Max weight on shelf	100 kg
Structure	1.2mm Steel
Cabinet color	Gray
Door	6 pcs, with handles, airtight magnetic sealers
ESD grounding wire	1M Ω
Voltage	220 V AC (110 V AC optional)
Power consumption	Ave. 56W/h
Castors	4 pcs, 2 of them with brakes



Model: SDF-1106-01

1%RH, 1708L

Drawing of SDF-1106-01

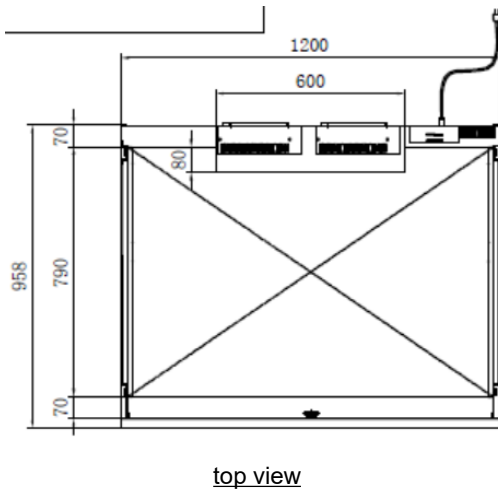
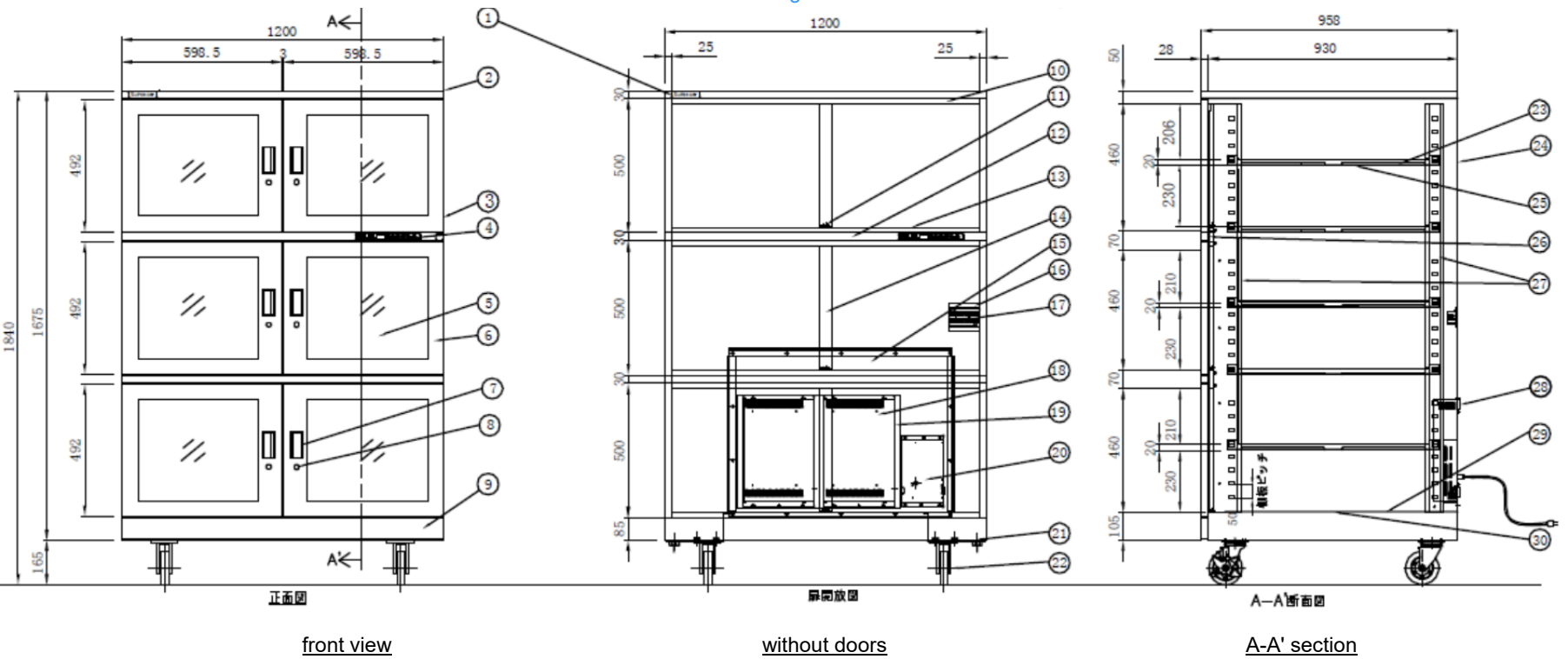

- ❖ Customized models with different dimensions are AVAILABLE.
- ❖ The max.external dimensions can be made into W1700mm, D960mm, H2000mm.

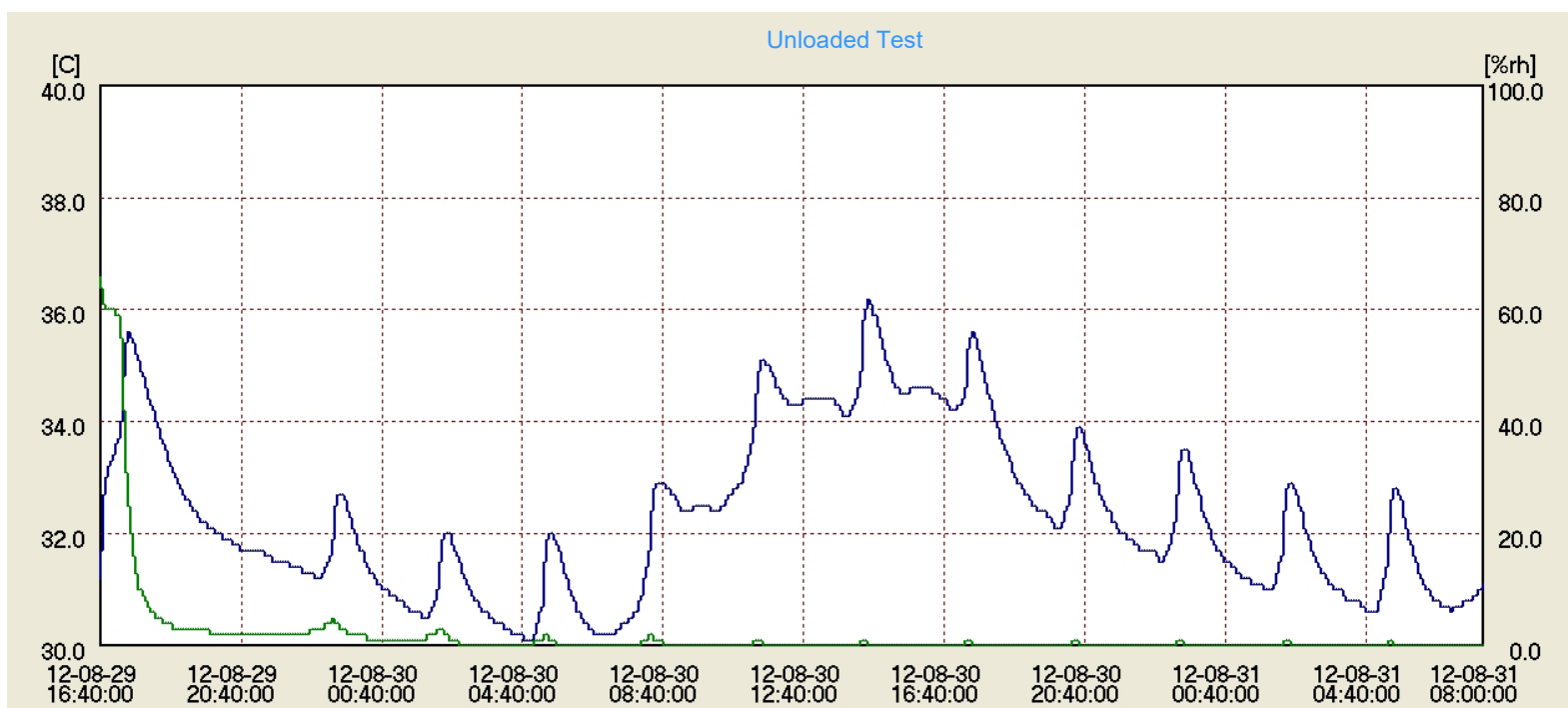
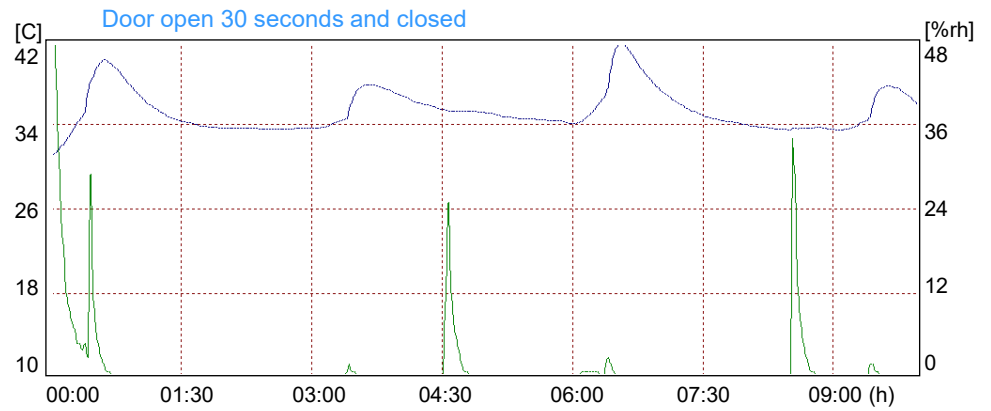

- ❖ Condition: 2012.08.29 16:40 ~ 2012.08.31 08:00
- ❖ Instrument: CHINO Data logger, Model: MR662. Accuracy rating: $\pm 0.5^\circ \text{C}$, $\pm 3\% \text{RH}$.



Model: SDF-1106-01

1%RH, 1708L

Digital Control Panel

- ❖ Set humidity value precisely, display humidity and temperature value
- ❖ Set the humidity and door open alarm
- ❖ Set the nitrogen purging time
- ❖ Lock the panel to avoid unintended changes of setting
- ❖ Sensor calibration



Available options



❖ Extra shelf

Greatly increase the usable space inside Super Dry

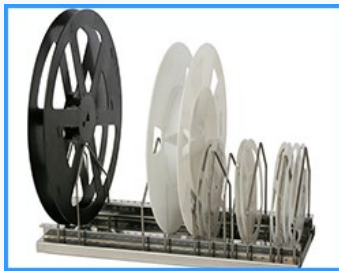

❖ SMD single rack (stainless steel)

Suitable for storage of components on tape and reel, can pull out on rail



❖ SMD double rack (stainless steel)

Suitable for storage of components on tape and reel, can pull out on rail



❖ Humidity/ Door open alarm buzzer

Alarm buzzer sounds when its internal humidity/ door open time exceeds set value

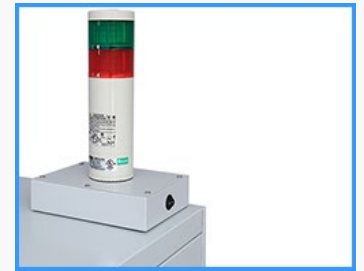

❖ Humidity alarm light

Alarm light flashes and sounds when its internal humidity exceeds set value



❖ Independent Nitrogen purge system (Model TN2-02)

Effective usage of N₂ combined with Super Dry, help to accelerate the recovery time and oxidation prevention. Set the buttons on N₂ purge system itself



❖ Nitrogen valve (Model: HN2-01)

Simple N₂ flow meter 0-25L/min adjustable



❖ Nitrogen auto purge system (Model AN2-03)

Effective usage of N₂ combined with Super Dry, help to accelerate the recovery time and oxidation prevention. Set on digital control panel



❖ Adjustable legs

Available for effective stabilization



Standard

❖ Wrist strap connection

Allows grounding while handling ESD sensitive materials



Standard

❖ Castors(4 pcs)

To move the cabinet on floor easily